

GE Consumer & Industrial
Power Protection

Technical Data Sheets

Digital Energy™ Uninterruptible Power Supply

LP 31 Series / 8 – 10 – 15– 20 kVA

400 Vac CE – Series 1

Date of issue: 10.07.2006



GE Consumer & Industrial SA

General Electric Company
CH - 6595 Riazzino (Locarno)
Switzerland
T +41 (0)91 / 850 51 51
F +41 (0)91 / 850 51 44

www.gedigitalenergy.com



GE imagination at work



Certified
Quality System
ISO 9001
Reg.No.CSQ 9130.GELE

GENERAL DATA					
Nominal output rating	kVA/kW	8/6.4	10/8	15/12	20/16
Overall efficiency at nominal load	%	92	92	92	92
Heat dissipation at inverter nominal load PF=0.8 and charged battery	kW	0.56	0.69	1.04	1.39
Cooling air (25°...30°C)	m ³ /h	165	205	305	405
Audible noise (EN 50091, load and temperature dependent)	dB(A)	40 - 50			
Operating temperature range	-10°C to 40°C (15 to 25°C recommended for battery)				
Storage temperature range	-20°C to +50°C				
Relative humidity	Max. 95%, non-condensing				
Protection degree	IP 20 (IEC 529 and DIN 40050)				
Safety	EN 50091-1-1; EN 60950 / IEC 60950				
EMC	EN50091-2				
Transport	On pallet / wheels for installation				
Colour	Cubicle: RAL 9010 (white) Front panel: aluminium				
Installation	Min. 10 cm room for free air flow				
Access for maintenance	At front and on sides of the cabinet				
External cable connections	On terminals, bottom-rear				
Ventilation	Forced by regulated internal fans				

INPUT CONVERTER (Rectifier + Power Factor Correction)					
Nominal AC input voltage	3 x 300...470V + N Rectifier accepted ph-ph voltage range: 300...470V				
Input frequency range	45-65 Hz				
Power factor	≥ 0.95				
Input current (no charging)	A	11	13	20	26
Inrush current	None				
DC output voltage	2 x 380 V				

BATTERY CHARGER					
Battery charging characteristic	IU (DIN 41773) constant current charging until floating voltage, then constant voltage charging				
DC input voltage range	2 X 350-450 V				
DC output voltage	2 X 271 V				
Output current limitation	Adc	2x2.1	2x2.1	2x4.2	2x4.2

BATTERY DATA					
Battery type	Sealed and maintenance free (VRLA = Valve Regulated Lead Acid))				
Float voltage at 25°C	2 x 271V				
Recharge time	1.5-3 hours for 80% capacity				
Number of 7Ah batteries (in standard version)		2x20	2x20	2x40	2x40
Standard autonomy time at nominal load PF=0.8	min.	14	10	13	10
Standard autonomy time with typical computer load	min.	17	13	16	13
Standard autonomy extensions	See table on page 4				

OUTPUT CONVERTER (Inverter)

Input voltage range	270 – 400V				
Nominal output power at PF=0.8	kVA	8	10	15	20
Nominal output power with resistive load	kW	6.4	8	12	16
Nominal AC output voltage	220/230/240V				
Output voltage tolerance					
- static resistive load	± 1%				
- dynamic mean deviation over half cycle (load step 0-100-0%)	± 2%				
- with measured non-linear load 2.5:1	± 2%				
- recovery time to ± 1%	10 ms				
Overload capability (battery operation)	120% ≥ 10 sec., 150% ≥ 2 sec.				
Short-circuit current capability	2.1 Inom during approx. 200 ms				
Output frequency	50 or 60 Hz				
Output frequency tolerance	± 0,1%, unless synchronised with mains				
Frequency tracking range	± 2% of nominal				
Output voltage waveform	Sinusoidal				
Max. phase shift difference input-output	7°				
Harmonic distortion with linear load	1% max.				
Harmonic distortion with non-linear load	5% max with measured crest factor 2.5:1				
Power factor range	Any lagging or leading power factor is permitted within the specified rating to PF=0.5				
Crest factor of the non linear load	5:1				
Output power derating temp.	Above 40°C: 5% per degree until 60°C				
Output power derating altitude	Up to 1000m no derating Above 1000m 12.5% per 1000m, max. 4000m				
Protection	Automatic shut down (or transfer to bypass if available) In case of: - low/high DC voltage - overtemperature - overload / short circuit Output protected against connection to the mains				
Short circuit clearance capability (selective)	20% In within 10 ms with MTCB class B				
Inverter bridge	PWM and IGBT technology				

BYPASS

Primary components	Thyristor switch Synchronisation circuit inverter/bypass mains
Bypass voltage limits	-15% +10% of nominal
Frequency tracking range	± 2%, 4% or 6% selectable
Slew rate	1Hz/s or 5Hz/s, selectable
Overload capability on bypass	120% ≥ 10min., 150% ≥ 2 min.

INTERFACING

Potential free Contact Interface	Four change-over contacts signalling following alarms: - bypass active - mains failure - battery low - general alarm
ComConnect port (on Delta 9 pin)	For serial communication
Input terminals for:	- Emergency Shutdown - Battery extension MCB alarm wiring

Note: all indicated values are typical. Variations may be found from one unit to another.

CONTROLS, SIGNALS, ALARMS

FRONT

Operation/Alarm	:	green/red LED
LCD screen	:	2 x 16 characters
Push-buttons	:	down / enter-reset / up
Buzzer (resettable)		
Inverter on/off switch		
Mains fuse (MCB)		
Bypass fuse (MCB)		

REAR

Interfaces	:	ComConnect (serial)
	:	Potentialfree contacts
	:	CardConnect slot
Manual bypass switch		
Input/Output terminals		

The LCD screen shows UPS system data, status messages, alarm messages, settings.

FRONT PANEL

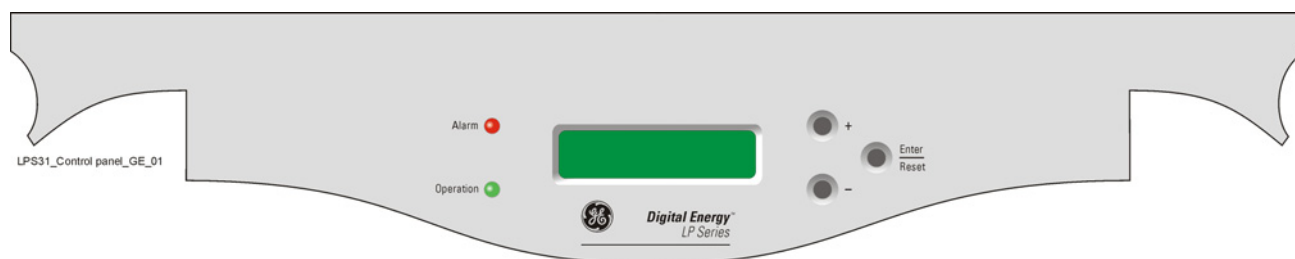

OPTIONAL FEATURES

SNMP Interface Card

An SNMP interface card can be placed in the CardConnect slot at the rear panel of the UPS, and allows the data interface to be connected directly to an Ethernet network.

When this option is installed the ComProt communication link (serial communication) is no longer available to the user.

Alarm Boxes

An *interface box* linked to the ComConnect port, the VIC/RELAYBOX/01 translates the ComConnect signals to five independent changeover contacts, with a maximum switching capacity of 230V/5A each.

Wall mounted plastic *alarm boxes* are available for remote audible and visual alarm indication.

Connectivity Products

A *splitter box* translates information from the ComConnect to several computers.

Interface kits (cables and software) are available for UPS communication with most commonly used network operating systems, including Novell, UNIX, VMS, Banyan Vines, Windows platforms, Apple, 3COM, IBM LANserver, IBM AS/400.

Please contact your dealer for specific information.

Battery Extension Packs

Extended run-time versions are equipped with additional batteries to increase the autonomy time of the unit.

Depending on model, the additional batteries are housed in the UPS itself or in separate battery cabinets and are connected in parallel to the standard battery.

The battery extensions are delivered with the necessary protection and connection material.

Additional batteries will increase the recharging time for the unit.

DIMENSIONS AND BATTERY TABLE

UPS Range	Autonomy time (min.)	Total capacity (Ah)	Nr. of extra battery cabinets	Battery cabinet (DTA-10) 410 mm (W) x 890 mm (D) x 925 mm (H) / 90 Kg			UPS cabinet (DT-10) 410 mm (W) x 890 mm (D) x 1190 mm (H = with wheels)												
				Weight cabinet with battery	Dimension & weight carton box		Dimension & weight wooden case		Weight without battery	Weight with battery	Dimension & weight carton box		Dimension & weight wooden case						
8 kVA	Without battery																		
	14 (*)	7 (*)	On UPS cabinet																
	36	14 (**)																	
	58	21	1	300 Kg															
	80	28 (**)	1	300 Kg	540 x 1030 x 1400 mm	325 Kg	540 x 1030 x 1400 mm	365 Kg	135 Kg	250 Kg	540 x 1030 x 1400 mm	275 Kg	380 Kg	540 x 1030 x 1400 mm	200 Kg	315 Kg			
	101	35	2	300 + 200 Kg															
123	42 (**)	2	300 + 300 Kg																
10 kVA	Without battery																		
	10 (*)	7 (*)	On UPS cabinet																
	25	14 (**)																	
	40	21	1	300 Kg	540 x 1030 x 1400 mm	325 Kg	540 x 1030 x 1400 mm	365 Kg	135 Kg	250 Kg	540 x 1030 x 1400 mm	275 Kg	380 Kg	540 x 1030 x 1400 mm	200 Kg	315 Kg			
	58	28 (**)	1	300 Kg															
	78	35	2	300 + 200 Kg															
96	42 (**)	2	300 + 300 Kg																
15 kVA	Without battery																		
	13 (*)	14 (*)	On UPS cabinet																
	33	28	1	300 Kg	540 x 1030 x 1400 mm	325 Kg	540 x 1030 x 1400 mm	365 Kg	150 Kg	365 Kg	540 x 1030 x 1400 mm	390 Kg	390 Kg	540 x 1030 x 1400 mm	215 Kg	430 Kg			
	55	42	2	300 + 300 Kg															
20 kVA	Without battery																		
	10 (*)	14 (*)	On UPS cabinet																
	25	28	1	300 Kg	540 x 1030 x 1400 mm	325 Kg	540 x 1030 x 1400 mm	365 Kg	150 Kg	365 Kg	540 x 1030 x 1400 mm	390 Kg	390 Kg	540 x 1030 x 1400 mm	215 Kg	430 Kg			
	41	42	2	300 + 300 Kg															

(*): Standard autonomy and capacity

(**): Additional 7Ah in the UPS cubicle

UPS BLOCK DIAGRAM

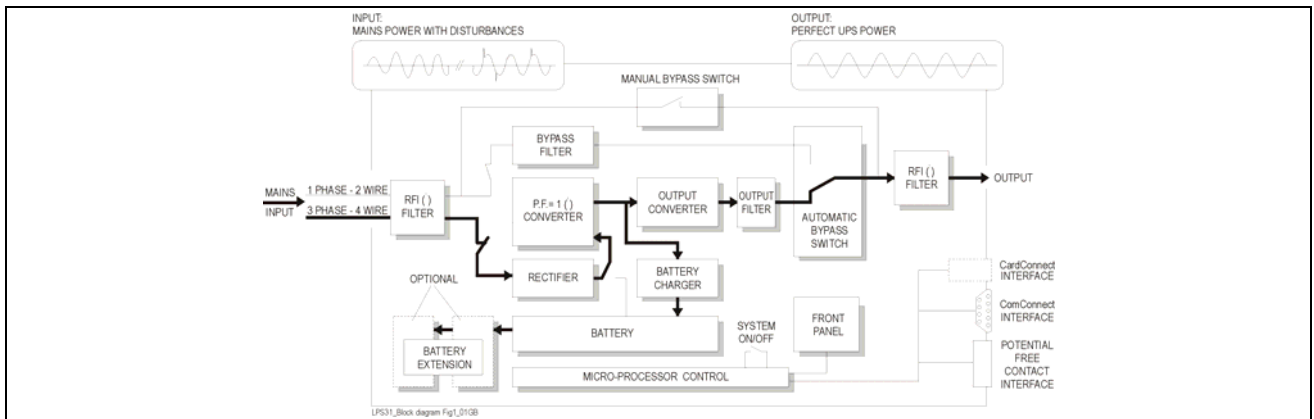

UPS needs two separate mains input:

Main input: 3-phase + neutral, the neutral connection is essential

Bypass input: single phase

Recommended external fusing of input wiring with mains 3x380/220V, 3x400/230V, 3x415/240V			Cable sections input and output recommended by European standards / in () SEV Alternatively, local standards to be respected	
UPS Model	Fuses gL / gG or Automatic Breakers		CABLE SECTIONS (mm ²)	
	Mains input	Bypass input	Mains input	Bypass input & system output
LP8-31	20A	40A	5 x 6 (5 x 6)	3 x 10 (3 x 10)
LP10-31	25A	50A	5 x 6 (5 x 6)	3 x 10 (3 x 16)
LP15-31	35A	80A	5 x 6 (5 x 10)	3 x 16 (2 x 25 + 16)
LP20-31	50A	100A	5 x 10 (5 x 16)	2 x 25 + 16 (2 x 35 + 25)