



Master Switch

STS Three-phase



Service
1st start



3:3 100-800 A
Static Transfer Switch

HIGHLIGHTS

- **High reliability**
- **Hot Replacement function**
- **3- or 4-pole version**
- **Advanced communications**

Installing a Master Switch static transfer switch provides additional resilience and protection from the disruption that can be caused by the failure of a single power source. The result is the absolute protection of industrial utilities and critical information technology against power supply and load faults.

OPERATING PRINCIPLE

Master Switch guarantees a source of redundant power, allowing the load to be switched between to alternative and independent power sources. Switching can be automatic (when a supply source falls outside of acceptable tolerances) or manually done by an operator from the front panel or remotely.

PROTECTION AGAINST POWER SUPPLY FAULTS

If one of the two power sources falls outside tolerance levels, Master Switch will transfer the consumers to the second power source (switching is instantaneous if the two sources are in phase).

PROTECTION AGAINST ENVIRONMENTAL DISTURBANCES

Overloads and load faults

In the event of an overload, the user can decide the level of intervention of the internal protection devices in order to block the power supply. In the extreme case of a downstream short circuit, Master Switch disconnects the load in order to avoid jeopardising the operation of the other loads (i.e. in the event of poor selectivity of the protection devices).

TOTAL MICROPROCESSOR CONTROL

Microprocessor control logic ensures:

- Fast and safe switching between power sources;
- Monitoring of all parameters via LCD display;
- Constant monitoring of SCR operation
- Advanced remote diagnostics (RS232 and TCP/IP).

REDUNDANT DESIGN

Power is supplied to the internal logic by two physically separate supply circuits that are fully independent and that can be replaced in “hot replacement” mode without causing power supply interruptions to the load. In the event that the power supplied by both sources fails, full system operation is guaranteed by the “Power Supply back up” function, which provides auxiliary power supply to the circuits from an external, independent power source. Master Switch is equipped with a dual redundant ventilation system known as: “fan redundance plus”. Thanks to this feature, and in the unlikely event that two fans fail at the same time, those remaining would still be able to dissipate the heat generated at nominal load and with an ambient temperature of up to 40° C. Also the fans can be replaced in “hot replacement” mode, ensuring continuity during the replacement operation.

SUPERIOR PROTECTION

In the event of an output short circuit, Master Switch blocks the transfer between the two power sources, eliminating the risk of propagating the short circuit and its effects to the other loads.

A back feed control circuit ensures the automatic intervention of the protection devices when a return of power to one of the two Master Switch inputs is detected.

ACCESSIBILITY

The layout of the moving components and parts is designed to ensure easy frontal access:

- power cable connections that are easily accessed with entry from below;
- boards housed in a dedicated area for rapid diagnosis / replacement;
- all parts subject to monitoring, maintenance and/or replacement.

ADVANCED COMMUNICATIONS

Master Switch provides information, measurements, statuses, and alarms via the LCD display. The STS is compatible with PowerShield³ supervision and shutdown software for Windows operating systems 10, 8, 7, Hyper-V, 2019, 2016, 2012, and previous versions, Mac OS X, Linux, VMWare ESXi, Citrix XenServer and other Unix operating systems.

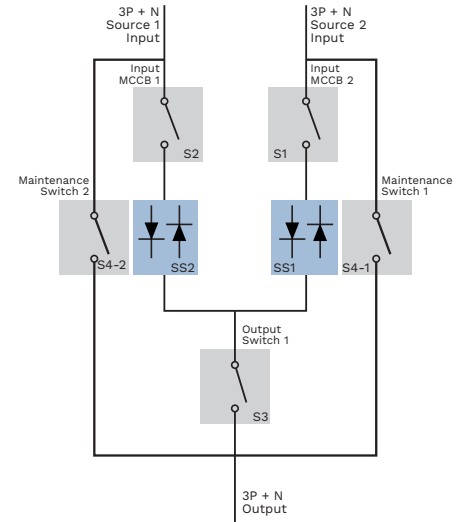

OPTIONS

SOFTWARE

PowerShield³
PowerNetGuard

ACCESSORIES

NETMAN 204
+ Communication card adapter
MULTICOM 302
+ Communication card adapter
MULTICOM 352
+ Communication card adapter

PRODUCT ACCESSORIES (ALL EX-WORK)

“No neutral on input” kit
IP rating IP31
Power Supply Back-up

DIMENSIONS

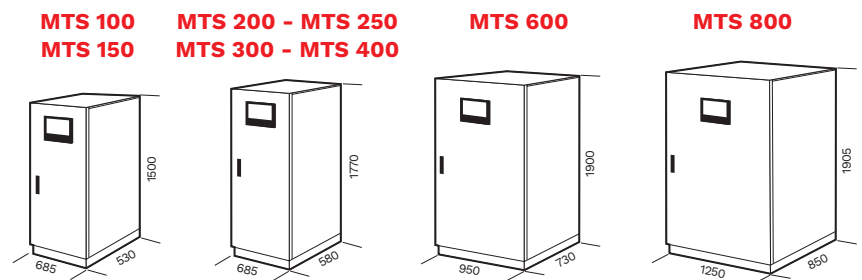

LEDs	FUNCTION
L1	S1 Priority Source
L2	S2 Priority Source
L3	S1 Present
L4	S2 Present
L5	Static transfer switch SS1 closed
L6	Static transfer switch SS2 closed
L7	Alarm indicator
L8	Output selector ON/OFF

5 function keys and LCD operation

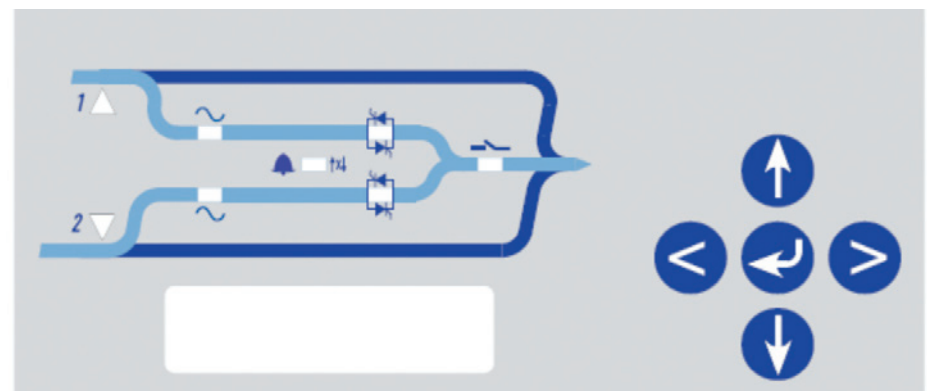

MASTER SWITCH IN REDUNDANT MODE

The secondary power source [AS], although highly reliable, only powers the load in the event of a failure with the priority power source [PS], ensuring maximum redundancy and power quality to the loads.

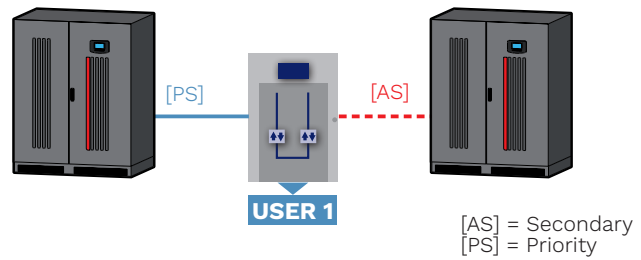

MASTER SWITCH IN CROSS FEEDING MODE

The two sources power critical loads using Master Switches configured to selected one of the two power sources as the priority source [PS]. In case of a failure in one of two sources, the other will be able to supply power to all the loads connected to the system.

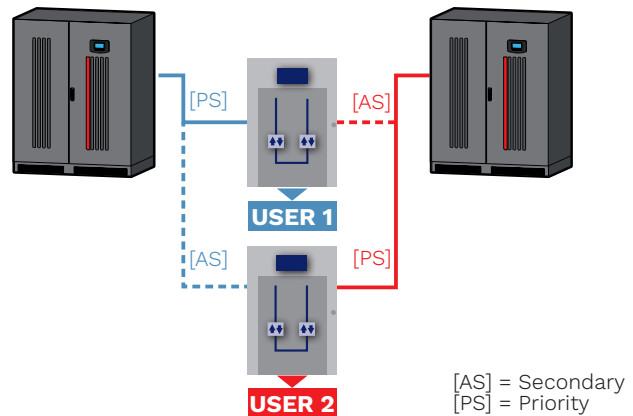

MASTER SWITCH IN BACK-UP MODE

Master Switches power utilities via the priority energy source [PS]; the secondary energy source [AS] is made up of independent, separate power sources and to make up for any faults in the priority power source [PS].

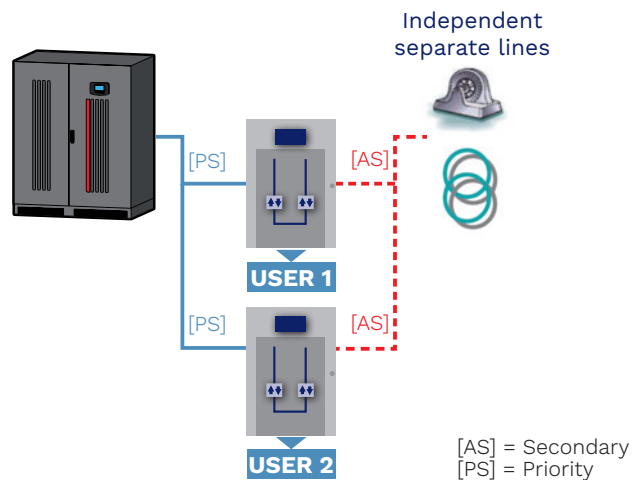

DYNAMIC DUAL BUS CONFIGURATION

The Riello UPS solution guarantees maximum reliability and ensures continuity of power supply under all operating conditions thanks to the UGS option that keeps the two systems, A and B, perfectly synchronised. The flexibility of the UGS system ensures synchronism between the sources even when one of the two systems is not a Riello UPS model, but made by another manufacturer, or when the input sources are not from uninterruptible power supplies.

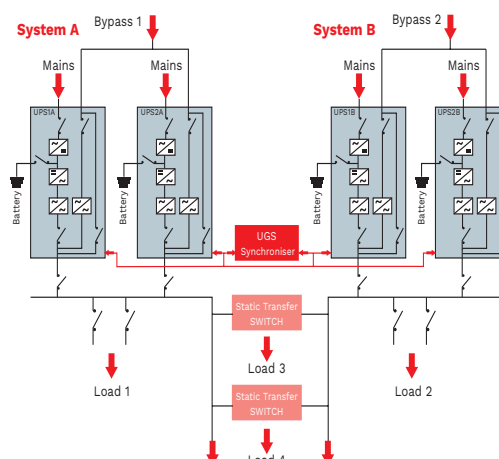

MODELS	MTS 100	MTS 150	MTS 200	MTS 250	MTS 300	MTS 400	MTS 600	MTS 800	
NOMINAL CURRENT	100 A	150 A	200 A	250 A	300 A	400 A	600 A	800 A	
INPUT									
Rated voltage - sources S1/S2 [V]	380 / 400 / 415 three-phase + N								
Voltage tolerance [V]	180 / 264 (selectable)								
Switched input phases	3+N (4-pole) - 3 (3-pole)								
Rated frequency [Hz]	50 / 60								
Input frequency tolerance range	±10% (selectable)								
Distribution compatibility	IT, TT, TNS, TNC								
OPERATING SPECIFICATIONS									
Transfer type	"Break Before Make" (no overlapping sources)								
Available transfer methods	Automatic / Manual / Remote								
Transfer time following source failure	<4 msec. (S1/S2 synchronised) 10 msec. (S1/S2 non synchronised)								
ENVIRONMENTAL SPECIFICATIONS									
Efficiency @ full load	>99%								
Noise at 1 m from front (from 0 to full load) [dBA]	55	55	55	55	55	55	<60	<62 dBA	
Storage temperature	-10 °C up to +50 °C								
Ambient temperature for the UPS	0 °C - +40 °C								
Range of relative humidity	5-95% non-condensing								
Max. installation height	1000 m at nominal power (-1% power for every 100 m above 1000 m) - Max 4000 m								
Reference standard	EN 62310-1 (safety) EN 62310-2 (electro-magnetic compatibility)								
OVERALL SPECIFICATIONS									
Weight [kg] 3 pole Type	150	155	195	200	225	230	340	515	
Weight [kg] 4 pole Type	155	160	205	210	235	240	375	560	
Dimensions (WxDxH) [mm]	685x530x1500		685x580x1770				950x730 x1900	1250x850 x1905	
Colour	RAL 7024								
IP rating	IP20								
Moving the STS	Pallet jack								

The information in this document is subject to change without notice. Riello UPS assumes no responsibility for any errors that may appear in this document. DATMTSR3Y20AREN